

Product description – Main components

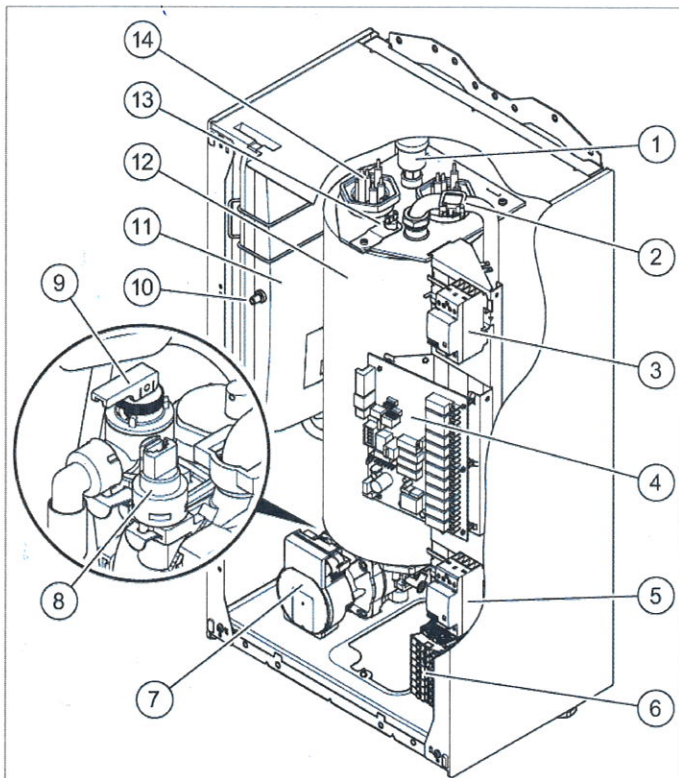

1 - Automatic air vent	2 - Flow sensor
3 - Contactor	4 - PCB
5 - Contactor	6 - Electric connection terminals
7 - Heating circuit pump	8 - Heating circuit pressure sensor
9 - Expansion relief valve	10 - Expansion vessel test valve
11 - Expansion vessel	12 - Heat exchanger
13 - Safety cut-out	14 - Heating element